

IC-PNEUMATIC

Diesel or LPG engine
Pneumatic Tires

CMP40
CMP45
CMP50s

4000 kg
4500 kg
5000 kg

CMP40/45/50s

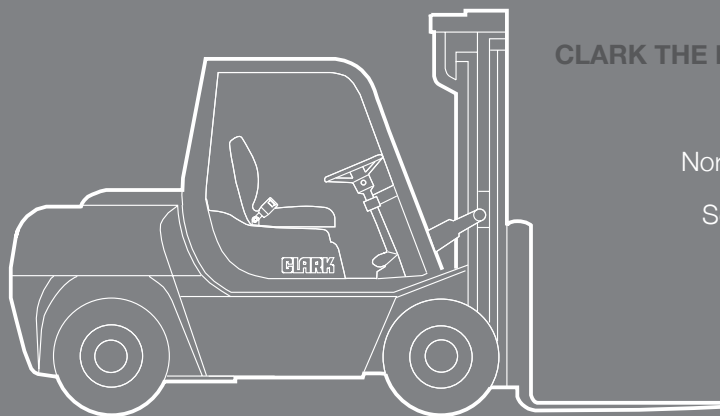

CLARK THE FORKLIFT

Europe

North America

South Korea

www.clarkmheu.com

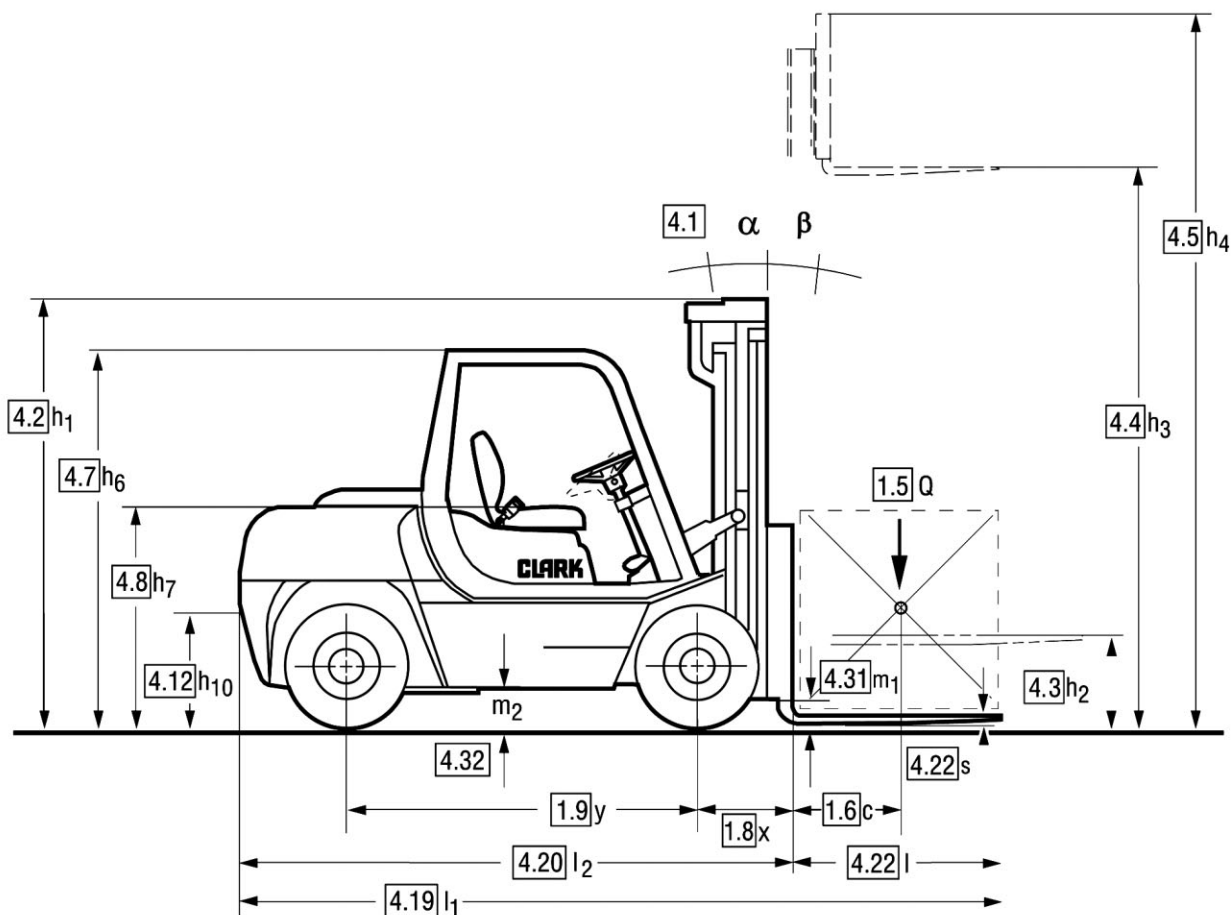

CMP40/45/50s

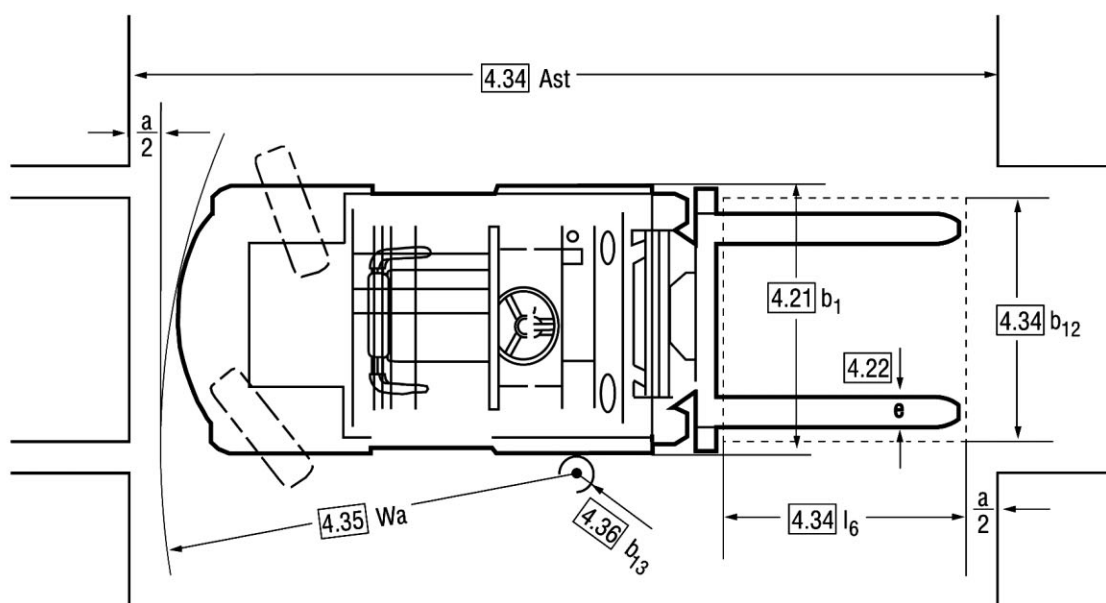

$$A_{st} = W_a + x + l_6 + a$$

$a = 200 \text{ mm (safety distance)}$

For corresponding data see
Specification Chart.

Truck Capacities

Capacity at different load centres

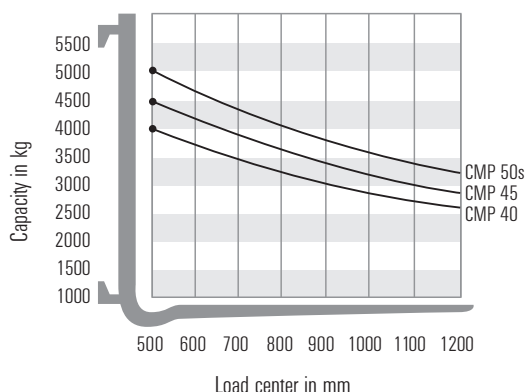

Note:

The listed capacities are valid only for the standard upright in vertical position with standard fork carriage and standard forks, up to max. lifting height of 3680 mm CMP 40-50s. The centre of gravity of the load may be displaced by max. 100 mm against the longitudinal centre line of the truck. Load centre is determined from top and front face of forks. The values are based on a 1000 mm cube load configuration with the centre of gravity at the true centre of the cube. With upright tilted forward lower capacity values are valid. Attachments, longer forks, exceptional load dimensions and higher lifting heights may reduce the capacity. Please contact your CLARK dealer if you require further information.

Upright table

Dimensions in mm

Upright table metrics in mm

CLARK Ref	max. fork height h3	overall height lowered h1	overall height raised h4*	free lift h2 h5*
-----------	---------------------	---------------------------	---------------------------	------------------

Standard CMP 40, 45, 50s L/D

(2 Stage Mast, standard free lift)

V	2000	1755	2750	100
V	2300	1905	3050	100
V	2500	2005	3250	100
V	2700	2105	3450	100
V	3000	2255	3750	100
V	3300	2405	4050	100
V	3500	2505	4250	100
V	3700	2605	4450	100
V	4000	2755	4750	100
V	4500	3005	5250	100
V	5000	3255	5750	100

* without LBR

Upright table metrics in mm

CLARK Ref	max. fork height h3	overall height lowered h1	overall height raised h4*	free lift h2 h5*
-----------	---------------------	---------------------------	---------------------------	------------------

Hi-Lo CMP 40, 45, 50s L/D

(2 Stage Mast, full free lift)

H	2700	2105	-	1530
H	3000	2255	-	1600
H	3300	2405	-	1760

* without LBR

Upright table metrics in mm

CLARK Ref	max. fork height h3	overall height lowered h1	overall height raised h4*	free lift h2 h5*
-----------	---------------------	---------------------------	---------------------------	------------------

Triple CMP 40, 45, 50s L/D

(3 Stage Mast, full free lift)

M	3700	2070	4505	1332
M	4000	2170	4805	1432
M	4300	2270	5105	1532
M	4500	2335	5305	1610
M	4800	2438	5605	1700
M	5000	2500	5805	1760
M	5500	2745	6305	2010
M	6000	2910	6805	2175
M	6500	3080	7305	2340
M	7000	3240	7805	2510

* without LBR

LPG engine

according to VDI 2198

All values shown are for standard lift truck with standard equipment. If the truck is supplied with options, values may change. All values given may vary +5% and -10% due to the motor and system tolerances and represent nominal values obtained under typical operating conditions. Specifications for Non-emission limited truck.

SPECIFICATIONS

1.1 Manufacture (Abbreviation)		CLARK	CLARK	CLARK		
Characteristics	1.2 Manufacture's designation	CMP 40 L	CMP 45 L	CMP 50s L		
	1.3 Drive Unit Diesel, L.P. Gas	L.P.-Gas	L.P.-Gas	L.P.-Gas		
	1.4 Operator type stand on / driver seated	driver seated	driver seated	driver seated		
	1.5 Load Capacity / rated load	Q (t)	4,0	4,5	5,0	
	1.6 Load Center distance	c (mm)	500	500	500	
	1.8 Load Center distance, centre of drive axle to fork face	x (mm)	570	570	580	
	1.9 Wheelbase	y (mm)	1950	1950	1950	
	Weight	2.1 Service weight	kg	6340	6570	6980
		2.2 Axle loading, laden front / rear	kg	8325/1277	9068/1261	9845/1393
2.3 Axle loading, unladen front / rear		kg	2725/3377	2668/3661	2645/4093	
Tires, Chassis	3.1 Tire type, P=pneumatic, SE=superelastic, C=cushion 1)	P	P	P		
	3.2 Tire size, front	8.25 x 15-14PR	8.25 x 15-14PR	300 x 15-18PR		
	3.2 Tire size, front - dual drive	7.50 x 15-12PR	7.50 x 15-12PR	7.50 x 15-12PR		
	3.3 Tire size, rear	7x12-14PR	7x12-14PR	7x12-14PR		
	3.5 Wheels, number front / rear (x=drive wheels 2)	2x (4x)/2	2x (4x)/2	2x (4x)/2		
	3.6 Tread, front	b ₁₀ (mm)	1295	1295	1245	
	3.7 Tread, rear	b ₁₁ (mm)	1150	1150	1150	
Dimensions	4.1 Tilt of upright / fork carriage, α/β	deg	10/8	10/8	10/8	
	4.2 Height, upright lowered	h ₁ (mm)	2405	2405	2405	
	4.3 Freelift	h ₂ (mm)	100	100	100	
	4.4 Lift height 3)	h ₃ (mm)	3300	3300	3300	
	4.5 Height upright extended 8)	h ₄ (mm)	4050	4050	4050	
	4.7 Height overheadguard (cab): Std / Container	h ₆ (mm)	2240	2240	2240	
	4.8 Seat high	h ₇ (mm)	-	-	-	
	4.12 Coupling high	h ₁₀ (mm)	-	-	-	
	4.19 Overall length	l ₁ (mm)	4160	4200	4390	
	4.20 Length to face of forks	l ₂ (mm)	3090	3130	3170	
	4.21 Width 2)	b ₁ /b ₂ (mm)	1550 (1900)	1550 (1900)	1550 (1900)	
	4.22 Fork dimensions	s/e/l (mm)	50 x 122 x 1070	50 x 122 x 1070	50 x 150 x 1220	
	4.23 Fork carriage DIN 15173, A, B		III A	III A	III A	
	4.24 Fork carriage width	b ₃ (mm)	1400	1400	1400	
	4.31 Ground clearance minimum, unladen 7)	m ₁ (mm)	173	173	173	
	4.32 Ground clearance center of wheelbase 7)	m ₂ (mm)	230	230	230	
4.34 Stacking aisle for pallets 800x1200 (l ₆ -b ₁₂)		4420	4450	4480		
4.34 Stacking aisle for pallets 1000x1200 (l ₆ -b ₁₂)	A _{st} (mm)	4620	4650	4680		
4.34 Stacking aisle for pallets 1200x800 (l ₆ -b ₁₂)	A _{st} (mm)	4820	4850	4880		
4.35 Turning radius	W _a (mm)	2830	2870	2900		
4.36 Internal turning radius 2)	b ₁₃ (mm)	-	-	-		
Performance	5.1 Travel speed laden/unladen	km/h	20,7/22,0	20,6/22,0	20,9/22,1	
	5.2 Lift speed laden/unladen	m/s	0,54/0,59	0,53/0,59	0,52/0,59	
	5.3 Lowering speed laden/unladen	m/s	0,47/0,44	0,47/0,44	0,47/0,44	
	5.6 Max. drawbar pull laden/unladen 5)	N	34398/16023 (30772/13130)	34623/15687 (30732/12787)	33839/15552 (30526/12591)	
	5.8 Max. gradeability laden 4) /unladen 5)	%	35,7/21,8 (32,3/20,8)	33,4/20,7 (30,0/20,0)	29,9/19,4 (26,8/19,2)	
	5.9 Acceleration time laden/unladen (0 - 15 m)	s	-/-	-/-	-/-	
5.10 Service brake		hydraulic	hydraulic	hydraulic		
Drive Line	7.1 Manufacturer / Type		GM/4.3 V6	GM/4.3 V6	GM/4.3 V6	
	7.2 Rated output acc. DIN 70 020	kW	62,4	62,4	62,4	
	7.3 Rated speed acc. DIN 70 020	min ⁻¹	2600	2600	2600	
	7.4 No. of cylinders / displacement	/cm ³	6/4294	6/4294	6/4294	
	7.5 Fuel consumption acc. VDI-Cycles	Diesel=l/h, L.P.Gas=kg/h	-	-	-	
Miscellaneous	8.1 Type of control		hydrodyn.	hydrodyn.	hydrodyn.	
	8.2 Operating pressure for attachments	bar	140	140	140	
	8.3 Oil volume for attachments	l/min	-	-	-	
	8.4 Sound level, driver's ear 6)	dB (A)	83	83	83	
	8.5 Towing coupling, class/type DIN		-	-	-	

1) Optional solid tires 2) Brackets for dual drive 3) For further lift heights, see upright table 4) Laden at 1.6 kph 5) Unladen at μ = 0.9

6) Equivalent permanent sound-pressure level L_{pAeq,T} in accordance with DIN EN 12053 7) Listed values can change with other tires and uprights 8) Without LBR

Diesel engine

according to VDI 2198

All values shown are for standard lift truck with standard equipment. If the truck is supplied with options, values may change. All values given may vary +5% and -10% due to the motor and system tolerances and represent nominal values obtained under typical operating conditions. Specifications for Non-emission limited truck.

SPECIFICATIONS

1.1 Manufacture (Abbreviation)		CLARK	CLARK	CLARK		
Characteristics	1.2 Manufacture's designation	CMP 40 D	CMP 45 D	CMP 50s D		
	1.3 Drive Unit Diesel, L.P. Gas	Diesel	Diesel	Diesel		
	1.4 Operator type stand on / driver seated	driver seated	driver seated	driver seated		
	1.5 Load Capacity / rated load	Q (t)	4,0	4,5	5,0	
	1.6 Load Center distance	c (mm)	500	500	500	
	1.8 Load Center distance, centre of drive axle to fork face	x (mm)	570	570	580	
	1.9 Wheelbase	y (mm)	1950	1950	1950	
	Weight	2.1 Service weight	kg	6340	6570	6980
		2.2 Axle loading, laden front / rear	kg	8325/1277	9068/1261	9845/1393
2.3 Axle loading, unladen front / rear		kg	2725/3377	2668/3661	2645/4093	
Tires, Chassis	3.1 Tire type, P=pneumatic, SE=superelastic, C=cushion 1)	P	P	P		
	3.2 Tire size, front	8.25 x 15-14PR	8.25 x 15-16PR	300 x 15-18PR		
	3.2 Tire size, front - dual drive	7.50 x 15-12PR	7.50 x 15-12PR	7.50 x 15-12PR		
	3.3 Tire size, rear	7x12-14PR	7x12-14PR	7x12-14PR		
	3.5 Wheels, number front / rear (x=drive wheels) 2)	2x (4x)/2	2x (4x)/2	2x (4x)/2		
	3.6 Tread, front	b ₁₀ (mm)	1295	1295	1245	
	3.7 Tread, rear	b ₁₁ (mm)	1150	1150	1150	
Dimensions	4.1 Tilt of upright / fork carriage, α/β	deg	10/8	10/8	10/8	
	4.2 Height, upright lowered	h ₁ (mm)	2405	2405	2405	
	4.3 Freelift	h ₂ (mm)	100	100	100	
	4.4 Lift height 3)	h ₃ (mm)	3300	3300	3300	
	4.5 Height upright extended 8)	h ₄ (mm)	4050	4050	4050	
	4.7 Height overheadguard (cab): Std / Container	h ₆ (mm)	2240	2240	2240	
	4.8 Seat high	h ₇ (mm)	-	-	-	
	4.12 Coupling high	h ₁₀ (mm)	-	-	-	
	4.19 Overall length	l ₁ (mm)	4160	4200	4390	
	4.20 Length to face of forks	l ₂ (mm)	3090	3130	3170	
	4.21 Width 2)	b ₁ /b ₂ (mm)	1550 (1900)	1550 (1900)	1550 (1900)	
	4.22 Fork dimensions	s/e/l (mm)	50 x 122 x 1070	50 x 122 x 1070	50 x 150 x 1220	
	4.23 Fork carriage DIN 15173, A, B		III A	III A	III A	
	4.24 Fork carriage width	b ₃ (mm)	1400	1400	1400	
	4.31 Ground clearance minimum, unladen 7)	m ₁ (mm)	173	173	173	
	4.32 Ground clearance center of wheelbase 7)	m ₂ (mm)	230	230	230	
4.34 Stacking aisle for pallets 800x1200 (l ₆ -b ₁₂)		4420	4450	4480		
4.34 Stacking aisle for pallets 1000x1200 (l ₆ -b ₁₂)	A _{st} (mm)	4620	4650	4680		
4.34 Stacking aisle for pallets 1200x800 (l ₆ -b ₁₂)	A _{st} (mm)	4820	4850	4880		
4.35 Turning radius	W _a (mm)	2830	2870	2900		
4.36 Internal turning radius 2)	b ₁₃ (mm)	-	-	-		
Performance	5.1 Travel speed laden/unladen	km/h	18,8/19,9	18,7/19,9	18,9/20,0	
	5.2 Lift speed laden/unladen	m/s	0,44/0,48	0,42/0,48	0,40/0,48	
	5.3 Lowering speed laden/unladen	m/s	0,47/0,47	0,47/0,47	0,47/0,47	
	5.6 Max. drawbar pull laden/unladen 5)	N	33678/17434 (33066/13130)	33818/17091 (32920/12707)	33170/16944 (33302/12591)	
	5.8 Max. gradeability laden 4) /unladen 5)	%	37,0/21,7 (35,0/20,8)	34,3/20,6 (32,5/19,6)	30,7/19,3 (29,0/19,2)	
	5.9 Acceleration time laden/unladen (0 - 15 m)	s	-/-	-/-	-/-	
5.10 Service brake		hydraulic	hydraulic	hydraulic		
Drive Line	7.1 Manufacturer / Type		Perkins/1104C-42	Perkins/1104C-42	Perkins/1104C-42	
	7.2 Rated output acc. DIN 70 020	kW	62,0	62,0	62,0	
	7.3 Rated speed acc. DIN 70 020	min ⁻¹	2400	2400	2400	
	7.4 No. of cylinders / displacement	/cm ³	4/4400	4/4400	4/4400	
	7.5 Fuel consumption acc. VDI-Cycles	Diesel=l/h, L.P.Gas=kg/h	-	-	-	
Miscellaneous	8.1 Type of control		hydrodyn.	hydrodyn.	hydrodyn.	
	8.2 Operating pressure for attachments	bar	140	140	140	
	8.3 Oil volume for attachments	l/min	-	-	-	
	8.4 Sound level, driver's ear 6)	dB (A)	84	84	84	
	8.5 Towing coupling, class/type DIN		-	-	-	

1) Optional solid tires 2) Brackets for dual drive 3) For further lift heights, see upright table 4) Laden at 1.6 kph 5) Unladen at μ = 0.9

6) Equivalent permanent sound-pressure level L_{pAeq,T} in accordance with DIN EN 12053 7) Listed values can change with other tires and uprights 8) Without LBR

CLARK CMP 40/45/50s Series pneumatic tire trucks are suited for wide ranging indoor and outdoor applications in manufacturing, warehousing and distribution operations. They are equipped with 2-speed powershift transaxles and are available with single and dual drive tires. These trucks are supplied with an high level of standard features.

Operator Control & Comfort

The CMP 40/45/50s Series trucks incorporate an isolated operator cell supported on rubber mounts that reduce vibration and sound transmission to the operator seat and controls. Low in-frame steps, 18.7 in. (475 mm) high, enable easy access to the cabin. A rubber floor mat makes footing secure. Seat deckmounted hydraulic control levers reduce fatigue through minimal required arm movement. Forward/backward movement of the electric directional control lever enables "finger tip" operation of the powershift transaxle; high/low range is selected by lifting/depressing the lever. Two-pedal inch-brake system provides excellent control and comfort. Left pedal is for inch and brake operation, right pedal for brake only.

Safety seat system provides protection in the event of a lateral overturn. The system, proven effective, includes lateral restraints, non-cinching seat belt with retractor and latching seat deck. Separate back and seat cushions are durable and comfortable; seat has 6 in. (150 mm) of front-to-back travel to accommodate small and large operators. Tilt steering wheel can be secured at any position within its range of travel. Rear hinged clamshell hood with gas cylinder assist makes access for daily inspection convenient.

Operator display monitor includes: Indicator lights for engine oil pressure, battery charge, transmission temperature, park brake "on", turn signal indicators and panel test light. Five digit hour meter and analog engine temperature and fuel gauges are provided on the display.

Diesel Engine

Perkins 1004.42, 4.0L 4-cylinder engines have iron block and cylinder head, 5 main bearing crankshaft and an internal dynamic balancer system that smooths engine vibration. Valve guides, exhaust valve seals and dry type cylinder sleeves are replaceable. New generation design incorporates low smoke, fuel efficient direct fuel injection and manifold type Thermostart system. Vertical exhaust is standard. Engine Accessories/Capacities: Trucks are 12-volt negative ground. Starters are equipped with heavy-duty clutch and anti-restart system. Batteries are 800 CCA at 0°F (-18 °C). All utilize heavy-duty air cleaners with pre-cleaners for added engine protection. Cooling system capacity is 16 qts. (16.9 L). Crankcase capacity is 2 gals. (7.6 L); Fuel tank capacity is 17.4 gal. (66 L). Service Access: Clamshell hood gives full access for inspections and service. Single piece floor panel is removable without tools. Filters are easily serviced and located to prevent spillage. Radiator is accessed, and removed easily, without counterweight or major component removal.

Transaxle

SF45 two-speed powershift transaxle is a single unitized driveline designed for reliability under maximum load and severe operating conditions. The transaxle features electric shift control that provides smooth engagement on start-up and on-the-fly shifts between low and high range. Electric shift control eliminates linkage wear and adjustment. A transmission oil cooler located in the engine

radiator extends transaxle life. Full-floating drive axle design adds durability as only torsional forces, not truck loads, are transmitted through the axle shafts. Service is enhanced by a readily accessible transaxle control cover and spin-on, full-flow lubricant filter.

Brakes

Hydraulic-operated wet disc brakes provide excellent brake performance and extended brake life. Brakes can be actuated from either left or right foot pedals. Left foot pedal also provides inching control. Disc/caliper-type parking brake on transmission is left hand-operated, and operator adjustable. Brake system reservoir is easily accessed on the front cowl.

Steering

Heavy fabricated steer axle incorporates an integral double-acting steer cylinder providing equal steering rate. Single-piece steer knuckles supported by tapered roller bearings provide high durability with low maintenance requirements. Full hydrostatic operation reduces mechanical links and eliminates kick-back. The axle is mounted in "silent block" cushion mounts that absorb shock and improve comfort. They require no maintenance.

Hydraulic System

The main hydraulic pump is direct driven by the engine crankshaft, providing reliability and separation from engine heat. Full-flow filter is located in the hydraulic tank providing continuous filtration. Hydraulic tank cover incorporates return line fittings, dipstick, and breather filter connection. Adjustable hydraulic valve eliminates unnecessary oil flow, energy loss and heat generation. Integral with-frame hydraulic tank dissipates hydraulic oil heat. Fluid capacity 17.1 U.S. gals. (65 L).

Upright Assembly

High visibility two-stage designs and are configured to provide maximum forward visibility. Interlocking rail/nested roller upright design utilizes specially rolled inner rail and channel section outer rails for high strength under heavy load conditions and greater tolerance to unbalanced load conditions. Uprights incorporate negative rail drop feature that enables upright rollers to be easily accessed for adjustment. Shaft type fork carriage incorporates six main rollers and four thrust rollers. Tilt cylinders incorporate spherical bushings at their mounting points to extend seal life by maintaining axial cylinder loads. Hydraulic counterbalance valve prevents improper tilt cylinder operation, flow limiting valves protect against rapid carriage descent in the event of a line failure, and a lowering control regulates lowering speeds. ITA Class III hook type carriages incorporate six main rollers and additional side thrust rollers too prevent binding when handling unbalanced loads. Forks are upset forged and have adjustable locks to maintain desired position. Forks are retained by the load backrest extensions.

Additional Features/Available Equipment

Color is high visibility CLARK Green with dark gray operator cell and upright. Wheels are bright white. Operator Manual is permanently attached to truck. Standard features include: 48 in. (1200 mm) high load backrest, recessed towpin, (4) built-in lift eyes, headlights, tail lights, and turn signals. CLARK's Employer's Guide to Material Handling Safety and operator safety video are provided with truck. Available equipment includes: integral sideshifter, steel cab with heater, rear work light, strobe light, audible alarm, mirrors, auxiliary hydraulic functions and attachments. Contact a CLARK representative for additional information.



CLARK Europe GmbH

Neckarstraße 37
D - 45478 Mülheim an der Ruhr
Tel. +49 208 377336 0
Fax +49 208 377336 36
email: info-europe@clarkmheu.com
www.clarkmheu.com

Your authorized CLARK dealer is: